

11435

Wireless Interactive Rugged Workstation

Standard Features

- Drip-Proof Ventilation
- Metal Construction (Vandal Resistant)
- 15", 768 x 1024, TFT LCD
- 1GHz CPU Intel Celeron M
- (4) USB, (3) COM, 10/100BT, (1) Gb Lan, (1) Keybd., (1) Mouse
- Wireless LAN (802.11G) with Antenna
- Wall Mount Bracket

The 11435 Series Workstation is a compact solution for your automation needs. System specs include a:



Specifications

LCD Display	Panel Type	TFT Active Matrix
	Maximum Resolution	768 x 1024
	Brightness	250 cd/m ²
	Viewing Angle	V ±70, H ±70
	Light Source	(2) CCFL 40,000 Hours
	Colors	16.7 Million
	Contrast Ratio	300:1
	Touchscreen	Surface Acoustic Wave
Mechanical	Size (W x H x D)	12" x 14.5" x 3.5" (304.8 x 368.3 x 88.9mm)
	Weight	13 lbs., (9 kg.)
	Material	Aluminum
	Finish	Wet Spray Class "A" Finish
	Rating	NEMA 1
	Humidity	10% - 90% RH
	Temperature (operating)	0 - 50°C
	(storage)	-20°C to +60°C
Electrical	Voltage	85 - 264VAC
	Current	0.34, max. @ 115 VAC
	Power Consumption	30 Watts
	Interface (I/O Ports)	KB/MS, (4) USB, (3) COM, 10/100BT, (1) Gb Lan
Processor	CPU	1.0 GHz Celeron M
	Slots	(1) PCI optional
	Memory	Up to 1 GB DDR RAM
	Video	Integrated Controller
	Sound	Integrated AC97 Audio
	LAN	10/100BT (Gbit Optional)
Peripherals	CF Drive	2 GB

11435

Dimensional Drawing

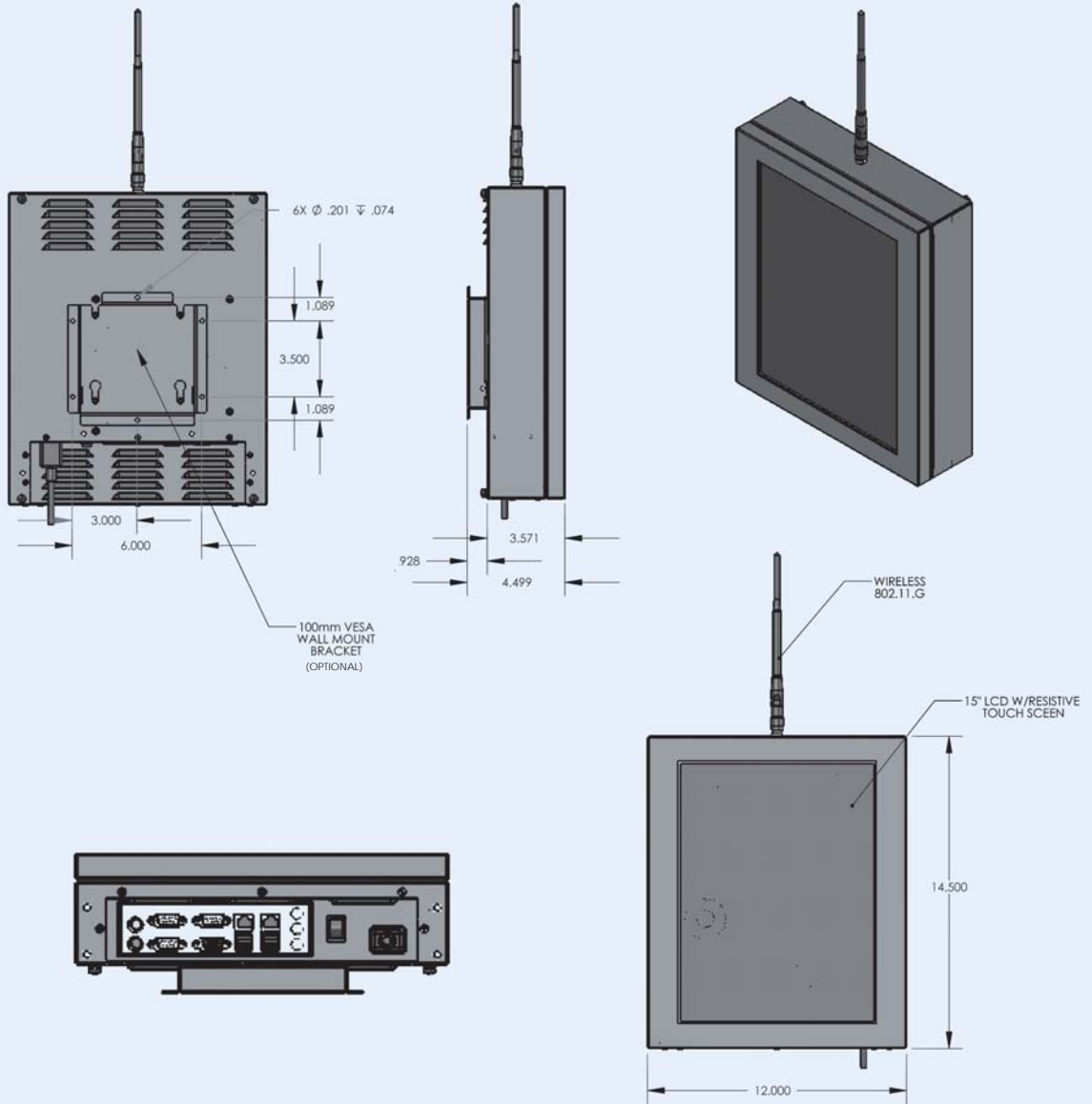

COMARK CORPORATION

93 West Street
Medfield, MA 02052

Toll Free 1-800-280-8522
Fax 508-359-2267
Local 508-359-8161

www.comarkcorp.com

Specifications subject to
change without notice.
Contact COMARK for
current pricing.

All brand names, trademarks
and registered trademarks
are the property of their
respective owners